

# SOCIAL NETWORK MODELING BY USING COUPLED OSCILLATORY SYSTEMS

Yoko Uwate<sup>1</sup> and Yoshifumi Nishio<sup>2</sup>

<sup>1,2</sup>Dept. of Electrical and Electronic Engineering,  
Tokushima University,  
2-1 Minami Jo-sanjima Tokushima 770-8506, Japan.

Email: <sup>1</sup>uwate@ee.tokushima-u.ac.jp; <sup>2</sup>nishio@ee.tokushima-u.ac.jp

**ABSTRACT:** In this study, we investigate the clustering phenomena in a social network of coupled chaotic circuits. We observe the various clustering phenomena in a social network model using coupled chaotic circuits when we change the scaling parameter of the coupling strength.

**KEYWORDS:** *Coupled oscillators, Chaotic circuits, Synchronization, Clustering, Social network and Community*

## 1.0 INTRODUCTION

Clustering phenomena is one of interesting nonlinear phenomena observed from coupled oscillatory systems. In our living life, clustering can be applied for many kinds of applications such as data mining, image processing and analysis of complex network structure. Therefore, there are many different clustering algorithms are developed in the different fields.

Recently, studies of social network have attracted attention from many researchers for creating efficient organization. Therefore, it is important to analyze the social network structure to find out the characteristics such as clustering phenomena. In order to process big data in social network, development of fast clustering algorithms is required.

On the other hand, coupled chaotic circuits can be realized by real electronic circuits and can observe various amusing phenomena. In recent years, many studies of coupled chaotic circuits have been reported by using different kinds of network topologies. We have investigated clustering phenomena in a simple network of coupled chaotic circuits [1], [2]. We believe that it is possible to apply the coupled oscillatory systems for clustering algorithms.

In this study, we focus on the clustering phenomena in a social network of coupled chaotic circuits. We propose novel clustering algorithm method by using synchronization states of the coupled chaotic circuits. For this investigation, the coupling strength is reflected the distance information when the chaotic circuits are placed on 2-dimensional space. We observe the various clustering phenomena in a social network model using coupled chaotic circuits when we change the scaling parameter of the coupling strength.

## 2.0 CHAOTIC CIRCUITS MODEL

In this section, we explain the chaotic circuit model. Figure 1 shows the model of the chaotic circuit, investigated in [3]-[5].

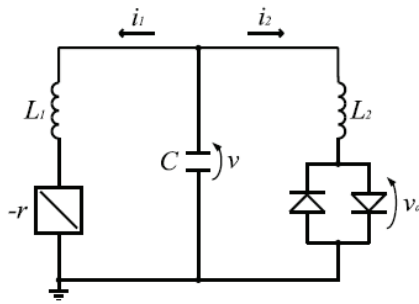

Figure 1: Chaotic circuit

Then the circuit dynamics are described by the following piecewise-linear third-order ordinary differential equations:

$$\begin{aligned}
 L_1 \frac{di_1}{dt} &= v + ri_1 \\
 L_2 \frac{di_2}{dt} &= v - v_d \\
 C \frac{dv}{dt} &= i_1 - i_2
 \end{aligned}
 \tag{1}$$

By changing the variables and using the parameters,

$$\begin{aligned}
 i_1 &= \sqrt{\frac{C}{L_1}} Vx, \quad i_2 = \frac{\sqrt{L_1 C}}{L_2} Vy, \quad v = Vz, \quad r \sqrt{\frac{C}{L_1}} = \alpha, \quad \frac{L_1}{L_2} = \beta, \quad r_d \frac{\sqrt{L_1 C}}{L_2} = \delta \\
 t &= \sqrt{L_1 C} \tau, \quad \dot{\phantom{x}} = \frac{d}{d\tau}
 \end{aligned}$$

That the Eq. (1) is normalized as

$$\begin{aligned} \dot{x} &= \alpha x + z \\ \dot{y} &= z - f(y) \\ \dot{z} &= -x - \beta y \end{aligned} \tag{2}$$

Where  $f(y)$  is described as follows:

$$f(y) = \frac{\delta}{2} \left( \left| y + \frac{1}{\delta} \right| \right) - \left( \left| y - \frac{1}{\delta} \right| \right) \tag{3}$$

The following equations show the circuit equations when all chaotic circuits are coupled via resistors by globally with each other.

$$\begin{aligned} \frac{dx_i}{d\tau} &= \alpha x_i + z_i \\ \frac{dy_i}{d\tau} &= z_i + f(y) \\ \frac{dz_i}{d\tau} &= -x_i - \beta y_i - \sum_{j=1}^N (z_i - z_j) \end{aligned} \tag{4}$$

(i, j = 1, 2, ..., N)

For the computer simulations, we set the parameters as  $\alpha=0.460, \beta=3.0$  and  $\delta=470$ . The characteristics of the function  $f(y)$  can be described 3-segment piecewise-linear function. In this study, the value of  $\gamma_{ij}$  reflects the distance between the chaotic circuits in an inverse way, described by the following equations:

$$\gamma_{ij} = \frac{g}{d_{ij}^2} \tag{5}$$

$d_{ij}$  denotes the Euclidean distance between i-th circuit and j-th circuit. The parameter  $g$  is a scaling parameter that determines the coupling strength.

### 3.0 CLUSTELING PHENOMENA IN A SOCIAL NETWORK

In this section, we show the obtained clustering phenomena by using the computer simulations. We configure the social network of the chaotic circuits in 2-dimentional space when 16 chaotic circuits are coupled globally. The arrangement of 16 chaotic circuits as a social network is shown in Figure 2(a). In these figures, we replace the chaotic circuits with a simple model like small circle.

We define the synchronization between two chaotic circuits when the phase difference is lower than 20 degrees.

Figures 2(b)-(f) show the synchronization process when the coupling strength is changed from  $g=0.000040$  to  $0.000200$ .

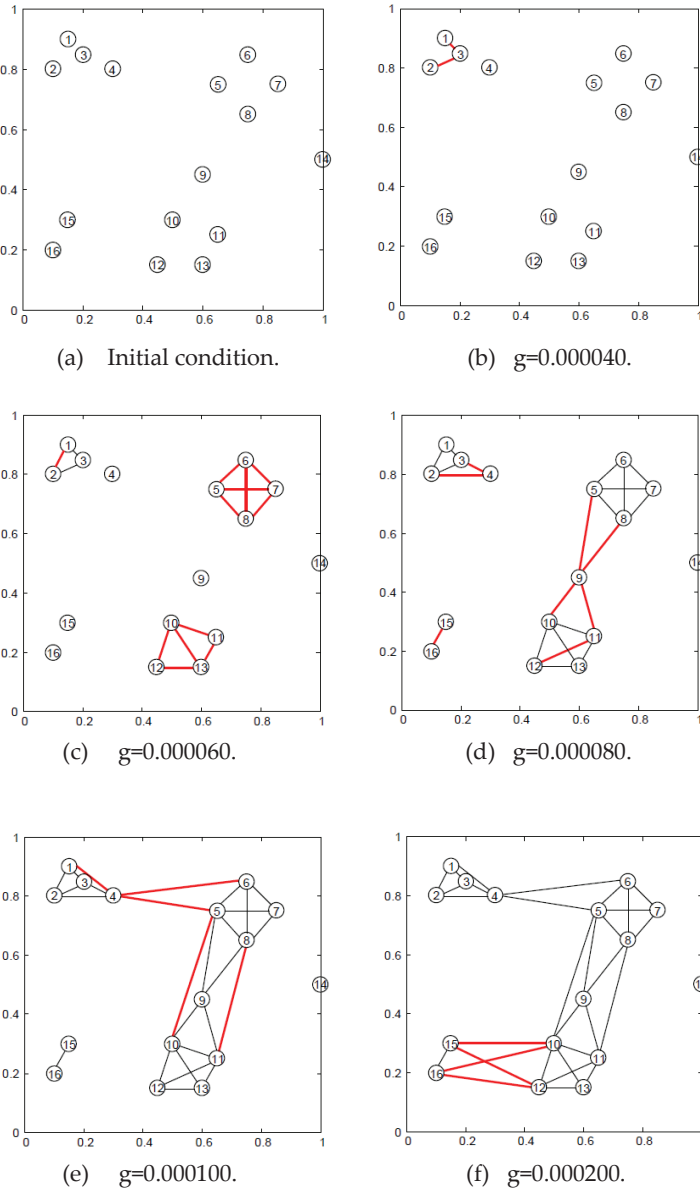

Figure 2: Clustering phenomena in a social network model (N=16).

From these figures, we confirm that the chaotic circuits located with high density are synchronized (see Figure 2(b)(c)). After that, the synchronization between the groups is occurred as shown in Figure 2 (d)-(f)).

The typical clustering patterns are shown in Figure 3. We divide the network to 5 groups when the coupling strength is fixed with  $g=0.000080$ . While, two groups are obtained when the coupling strength is fixed with  $g=0.000200$ . By using the coupled chaotic circuits for analyzing social networks, it is possible to observe several types of clustering pattern by changing the coupling strength.

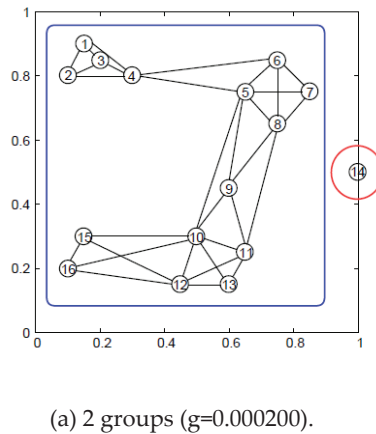
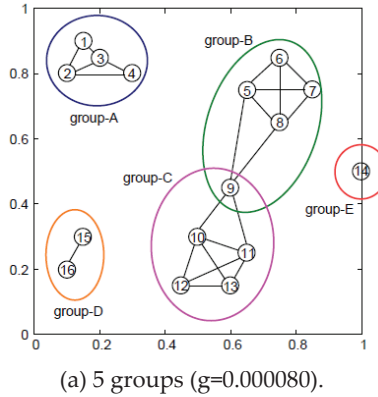

Figure 3: Groups in a social network model with the coupling strength ( $N=16$ ).

#### 4.0 CONCLUSION

In this study, we have investigated the clustering phenomena in a social network of coupled chaotic circuits. We observed the various kinds of clustering phenomena by changing the scaling parameter of the coupling strength. We can see that the clustering phenomena depends on the arrangement and density of the chaotic circuits in the network.

In the future works, we would like to apply this approach for more large-scale social networks. Furthermore, we would like to focus on community structure in a social network.

## **ACKNOWLEDGMENTS**

This work was partly supported by JSPS Grant-in-Aid for Challenging Exploratory Research 26540127.

## **REFERENCES**

- [1] Y. Takamaru, H. Kataoka, Y. Uwate and Y. Nishio, "Clustering Phenomena in Complex Network of Chaotic Circuits". *Proc. of ISCAS'12*, pp. 914-917, May 2012.
- [2] Y. Takamaru, Y. Uwate, T. Ott and Y. Nishio, "Clustering Phenomena of Coupled Chaotic Circuits for Large Scale Networks". *Proc. of NDES'12*, pp. 70-73, Jul. 2012.
- [3] Y. Nishio, N. Inaba, S. Mori and T. Saito, "Rigorous Analyses of Windows in a Symmetric Circuit". *IEEE Transactions on Circuits and Systems, Vol. 37*, no. 4. pp. 473-487, Apr. 1990.
- [4] C. Bonatto and J. A. C. Gallas, "Periodicity Hub and Nested Spirals in the Phase Diagram of a Simple Resistive Circuit". *Phys. Rev. Lett.*, 101, 054101, Aug. 2008.
- [5] R. Stoop, P. Benner and Y. Uwate, "Real-World Existence and Origins of the Spiral Organization of Shrimp-Shaped Domains". *Phys. Rev. Lett.*, 105, 074102, Aug. 2010.